

SB5000

Vehicle Serial Bus Analyzer



Comprehensive waveform measurement and protocol analysis for automotive serial buses, including FlexRay, CAN, LIN and UART, in one instrument.



Advanced Functions for FlexRay Waveform & Protocol Analysis

Comprehensive In-Vehicle Serial Bus Analyzer

The SB5000 Vehicle Serial Bus Analyzer is an invaluable tool for engineers involved in the development and use of in-vehicle communication buses. It can analyze FlexRay, an emerging bus technology employed by advanced ECU's and electronic vehicle control applications. Because it can measure logic signals of up to 32 bits simultaneously, a single SB5000 offers measurement and analysis of parallel bus signals from microprocessors and other sources.

- FlexRay, CAN, LIN, UART, I²C, and SPI bus triggers and analysis
- FlexRay eye-diagram analysis
- Characterizes electrical characteristics parameters of the FlexRay bus driver
- CAN/FlexRay *1 bus symbolic triggering, analysis, decoding, and trend display (Supports DBC database for CAN, FIBEX database for FlexRay)
- 4 ch analog + 8-bit logic (SB5310)
4 ch analog + 32-bit logic (SB5710)
- Up to 5 GS/s, 1 GHz bandwidth, 6.25 MW (Mpts) memory
- Auto Setup Dedicated to Serial Busses

*1: Available on the firmware version 4.20 or later.



+ UART, I²C and SPI

Measure and Analyze 3 Vehicle Serial Buses + 3 General Purpose Serial Buses, and 32-Bit Max Parallel Buses—All on a Single Instrument



Vehicle Serial Bus Analyzer **SB5000**

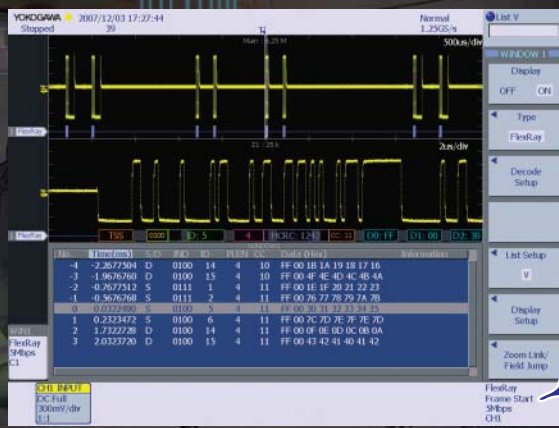

Figure.1 FlexRay waveform, list, decode display example

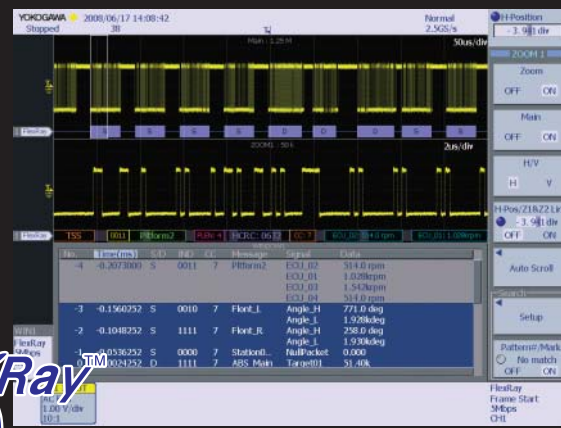

Figure.2 FlexRay FIBEX symbolic decode, analysis list display example

Easy and efficient observation of the physical layer and simultaneous protocol analysis enable you to evaluate the performance of your FlexRay communication system. Evaluation and test through long-duration (multiple-cycle) bus observation answer questions such as whether specific frames are being transferred as designed, whether there are any "glitches" in signals, or whether any data corruption is occurring. The FlexRay FIBEX symbolic triggers, analysis and trend display functions *2 allow you to activate trigger and display the analysis results by physical values (Message and Signal) in conformity to FIBEX database.



Figure.7 CAN waveform, list, decode display example

In-vehicle networks are standardized by specific use, and the optimal protocol is used for each application. The SB5710/SB5310 supports analysis of CAN, today's standard backbone network and control protocol. Like the FlexRay analysis functions, the instrument comes standard with abundant CAN bus triggers and robust analysis functions.

FlexRay

CAN

In addition to Frame Start, ID, Cycle Count, Data, and other conditions, the SB5710/SB5310 serial bus analyzer allows you to trigger on CRC, BSS, and FES errors to capture physical layer voltage waveforms. The protocol analysis results list and decode displays are shown simultaneously with the waveform display which is updated in real time on every trigger (Figure 1). If a communication abnormality occurs, this helps you to identify causes including whether the problem is hardware or software related. The analysis results list can be saved to a text file in csv format. You can make a "Field Jump" in the zoom screen to the top of a specific field in a specific frame (the CRC field, for example), or search the entire range of captured data for the field's waveform by specifying field and frame conditions.

FlexRay Eye-Diagram Analysis

With the SB5710/SB5310, you can perform mask and eye parameter tests (Figure 3) conforming to the eye-diagram evaluation methods defined by the FlexRay Physical Layer Conformance Test Specification. From the accumulated test pulses, you can perform the mask test to calculate the number of abnormal pulses, number of waveform samples in the abnormal portion, and their ratio, and display the results. You can also perform the same mask and eye parameter tests on a specific bit specified in the on-screen zoom box (Figure 4). Up to six mask patterns, including ones defined by the FlexRay specifications, can be stored in the unit and recalled as needed according to the type of test to be performed. You can also edit masks after recalling them.

Testing the Electrical Characteristics of the Bus Driver

The SB5710/SB5310 comes with functions for calculating parameters required for electrical characteristics tests of the bus driver (timing measurements of the transmitter and receiver operation). By simply selecting parameters for the source channel and the circuit under test in an easy-to-understand graphical menu, you can easily determine various delay times, rise/fall time, absolute value of differential voltage, and other values.

Evaluating Fluctuations in Communication Delay and Cycle Time

The SB5710/SB5310 measures BSS bit time intervals from captured FlexRay communication data, and can also calculate relevant statistics (Figure 6). It supports time interval measurements and statistical calculation of every BSS, every BSS in frames of a specific ID, and the first BSS in specified frames or cycles.

It is also equipped with dedicated CAN triggers including Start of Frame, ID, Data, Remote Frame, and Error Frame. Additionally, you can now set up to four ID and Data combination bit conditions and activate triggers based on OR relationships of these combinations. With the protocol analysis results list which is shown in a time series fashion (Figure 7), you can check each frame's analysis results (frame type, time from trigger point, ID, DLC, Data, and CRC), presence/absence of Ack, and the association with corresponding waveforms in a single screen. You can specify the type and other characteristics of fields and frames and search for corresponding waveforms in the captured CAN frame data.

Analysis and Waveform Display of Two Busses Simultaneously

You can analyze two CAN bus signals of differing conditions (for example, Hi-Speed and Low-Speed CAN) simultaneously, and display the analysis results along with waveforms. This allows verification of the correlation between the data on the upstream (backbone) network CAN bus and the downstream (sub) network. You can observe bus waveforms of different bit rates by zooming one each in the two zoom areas (Figure 8).

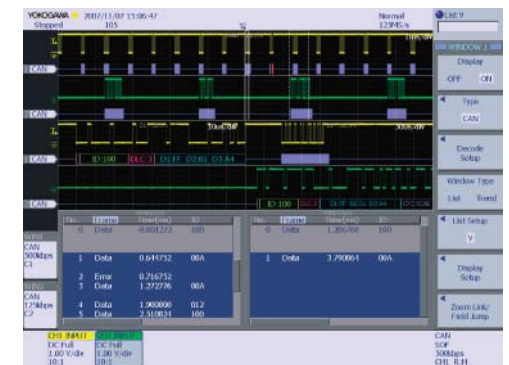

Figure.8 Example of 2-bus simultaneous waveform & decode display

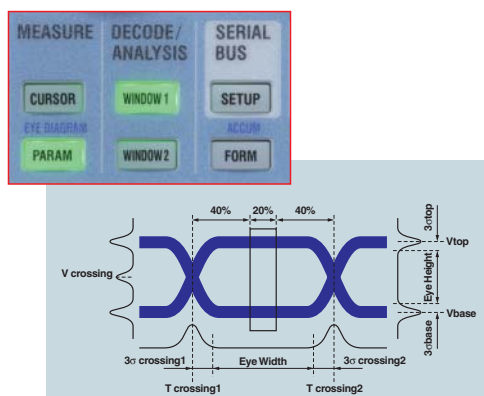

Figure.3 Eye Parameter Items



Figure.4 Eye-diagram analysis example

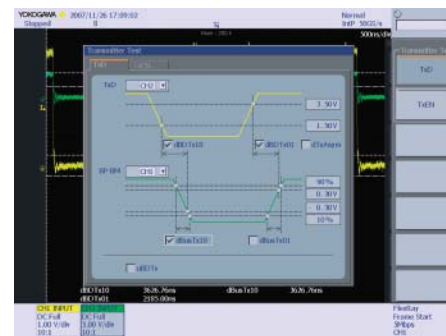

Figure.5 Example of electrical characteristics parameters of the FlexRay bus driver

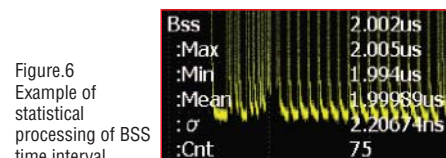

Figure.6 Example of statistical processing of BSS time interval

Symbolic Triggering, Analysis, and Trend Display

You can load physical value definition files (FIBEX/DBC database files with extension .xml/.dbc), enter trigger settings based on physical values (Message and Signal), and display analysis results as physical values (decoding). You can read physical values directly from waveforms, allowing increased efficiency of troubleshooting and analysis of faults in the FlexRay/CAN network. Also, you can specify a particular Message/Signal from the captured FlexRay/CAN data (Figure 10, top) and display its physical values in a trend graph (Figure 10, bottom).

The dedicated PC-software for Symbol definition (Symbol Editor) allows you to convert from FIBEX/DBC Database file into physical(Message, Signal) value file. Then the physical value file can be imported into the SB5710/SB5310. The Symbol Editor can be free downloaded from our web site shown below. <http://www.yokogawa.com/tm/SB5000/>

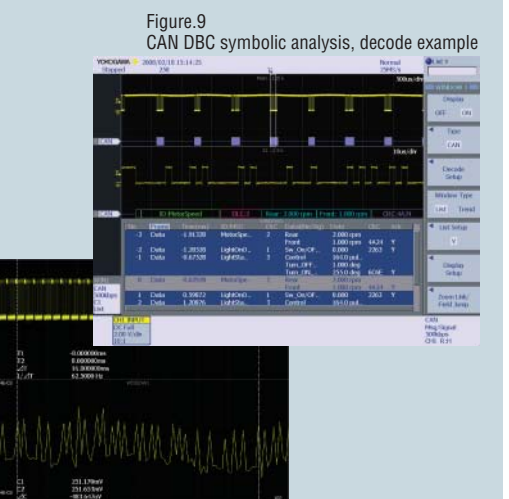
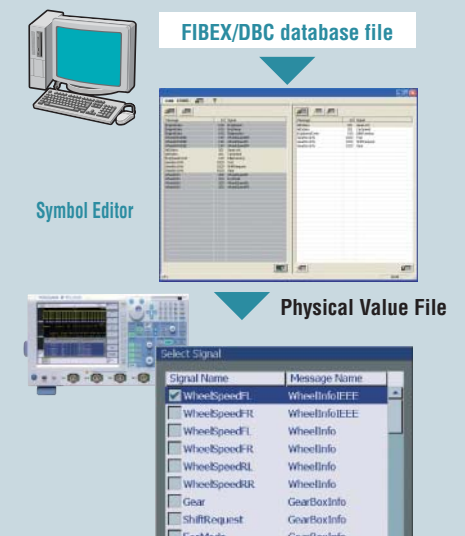

Figure.10 FlexRay/CAN symbol data trend display example

*2: Compatible with the FIBEX version 2.0

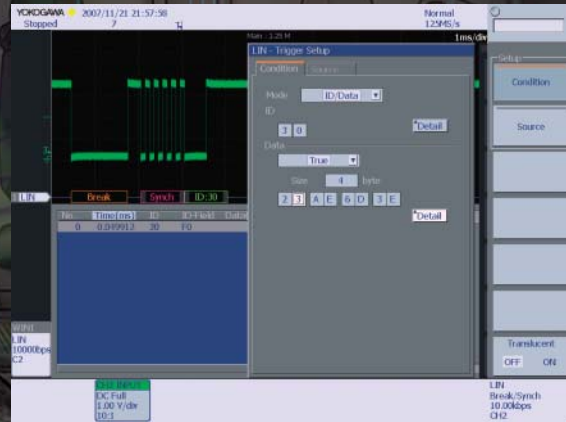

Figure.11 LIN trigger setting example



UART

I²C, SPI

LIN

Comprehensive triggering, powerful analysis tools, and captured data searching functions are also provided for the LIN bus (body subnetwork). And speaking of triggers, the SB5710/SB5310 is equipped with not only Break + Synch and ID/Data (combinable) conditions, but also with a wealth of error triggers. This is one of the major features of the SB5710/SB5310. You can capture bus waveforms when the various errors defined by the LIN protocol specifications (Parity, CheckSum, TimeOut, etc.) occur, and check those waveforms and the protocol analysis results (list) along with the error information. You can analyze both LIN revision 1.3 and 2.0 conformity data existing on the same bus line simultaneously.

Figure.12 LIN waveform, list, decode display example



Figure.13 LIN revision 1.3 and 2.0 simultaneous decode, analysis display example

Combination Triggers: Create triggers consisting of in-vehicle bus events and events on other channels (e.g., a sensor input, or another in-vehicle bus event) (Event Interval Trigger)

• Trigger on Combinations with Non-in-vehicle bus Signals

Triggers can be activated on combinations of in-vehicle bus and analog signal trigger conditions. For example, you can debug a system by setting up a condition in which the trigger activates on a time difference between a LIN signal trigger condition and a signal input to another channel such as a sensor or actuator operation signal.

• Trigger on Combination of Two in-vehicle bus Signals

You can set a condition in which a trigger activates on the time difference (delay time, etc.) between trigger conditions set on two separate in-vehicle bus networks. This is useful for verifying the complementary operation of two corresponding sub-networks.

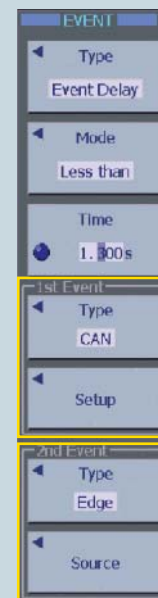

Figure.14 Event Interval Trigger setting example

From CPU communication data in the ECU (electric control unit) to communication signals in manufacturing facilities, communication via a general purpose UART is carried out in a broad range of fields—among them, automobile development. The SB5710/SB5310 supports general-purpose UART trigger and analysis functions. Figure 15 to 17 show examples of the UART trigger setting screen and the waveform and analysis results display, respectively.

Check Signal Conditions When Trouble Occurs with Flexible UART Triggers and Error Triggers

In addition to specifying conditions of 8-bit data (with/without parity bit) and 7-bit data + parity bit, the UART trigger function supported by the SB5710/SB5310 can search for and trigger on parity and framing errors. Analysis number, time from trigger position, binary and hexadecimal notation of data, errors, and other added information can be linked with the waveforms and displayed in the same screen as analysis results.

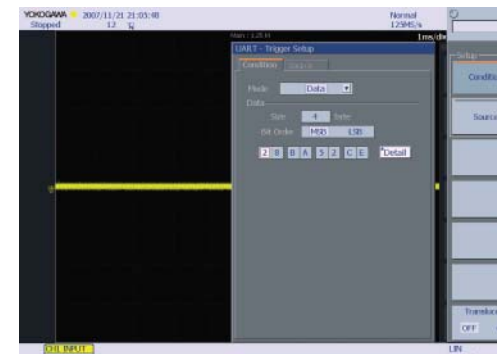

Figure.15 UART trigger setting example

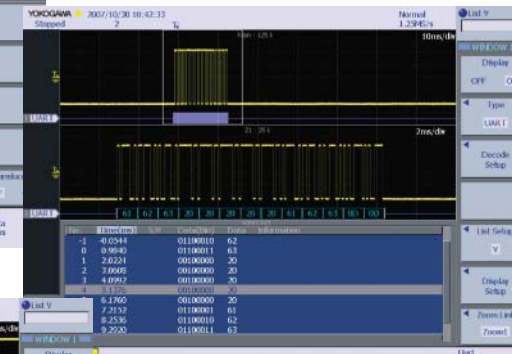

Figure.16 UART waveform, list, decode display example 1

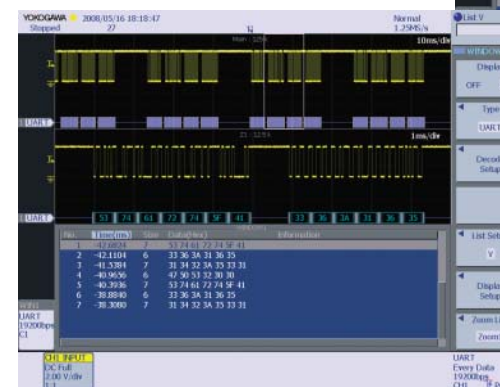

Figure.17 UART waveform, list, decode display example 2 (grouping display)

The SB5710/SB5310 also comes standard with trigger and analysis functions for the I²C and SPI general-purpose serial buses that are widely used as internal buses in car navigation and car audio systems. Figure 18 shows an example of measurement on an I²C bus, and Figure 19 gives an example of simultaneous display of waveform capturing and the analysis results list on the SB5710/SB5310.

The various kinds of serial bus analysis functions required in the automobile development process come standard on the SB5710/SB5310; a single instrument supports development and evaluation in a variety of scenarios.

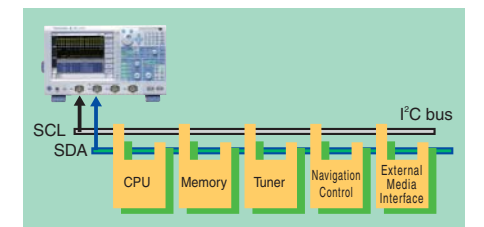

Figure.18 I²C bus measurement application example

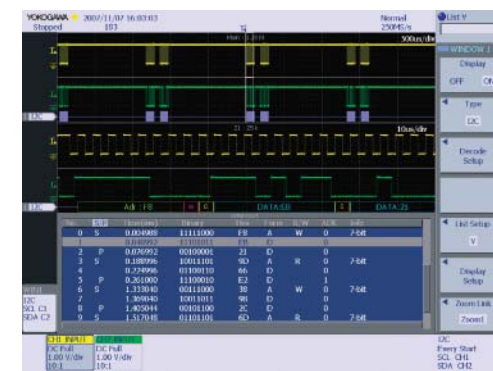

Figure.19 I²C waveform, list, decode display example

Making It Easier

Dedicated Menus and Auto Setup Dedicated for Serial Buses

The SB5710/SB5310 represents our constant pursuit of "more analysis functions that are easier-to-use." All in-vehicle serial bus analysis functions can be intuitively accessed and operated by following a menu displayed with the "SERIAL BUS SETUP" key. Furthermore, using the Auto setup function dedicated for serial buses, you can have the instrument automatically enter settings for record length, time axis (T/div), triggers, and analysis by simply specifying bus type and source (input) channel. After that, it will automatically display bus waveforms and analysis results (list and decoding). This frees you from tedious analysis setup.

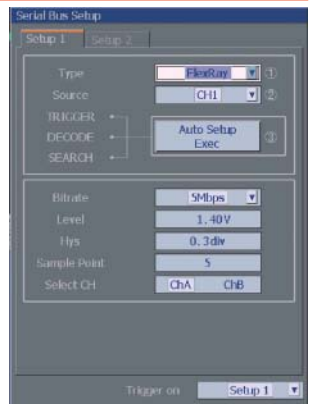

Figure.20 Dedicated setup display for serial buses

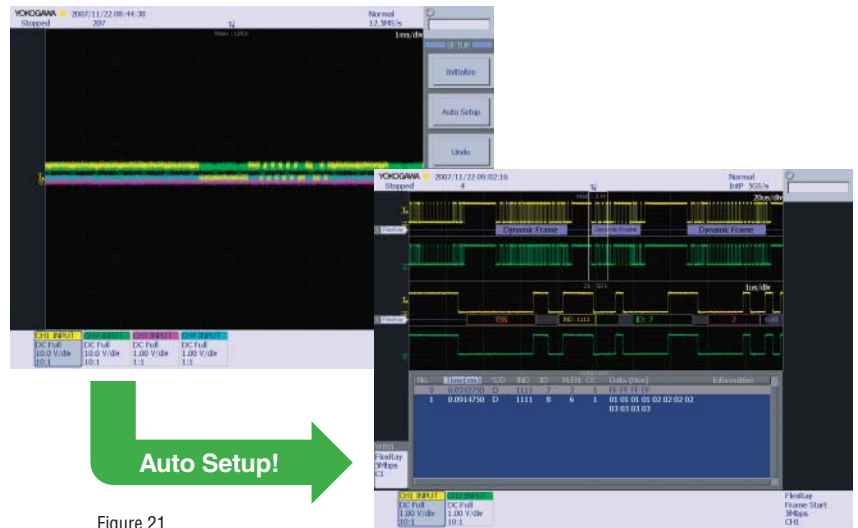

Figure.21 Serial bus auto setup function

Logic Signal (Parallel Bus) Measurement and Analysis

The SB5710/SB5310 can simultaneously measure and analyze logic signals of up to 32-bits (available as 32-bit or 8-bit models). It is effective for ECU debugging because simultaneous measurement and analysis applies not only to in-vehicle serial buses (measured on analog channels), but also to parallel bus signals. The SB5710/SB5310 also supports the state display and bus display functions that is standard on logic analyzers. The fast screen update rate is maintained even when measuring analog and logic signals at the same time. Measuring logic signals requires the model 701980 or 701981 logic probe (sold separately).

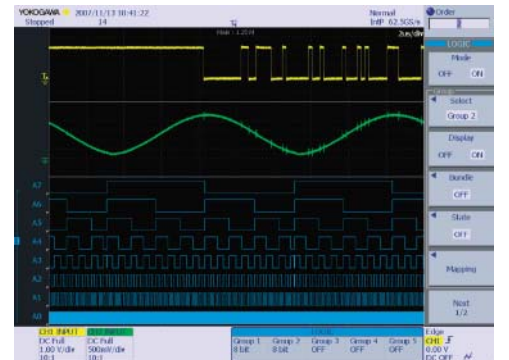

Figure.22 Example of simultaneous observation of analog & logic signals

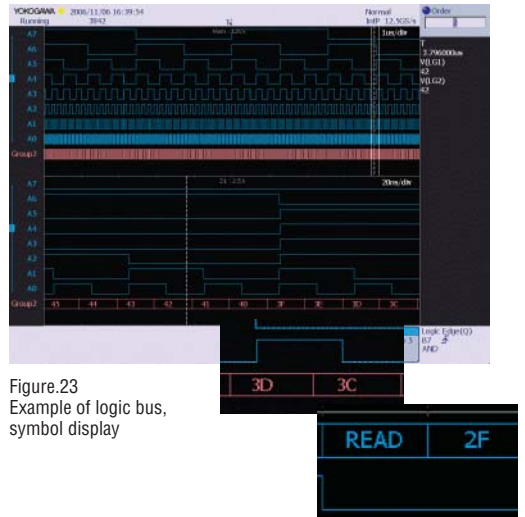
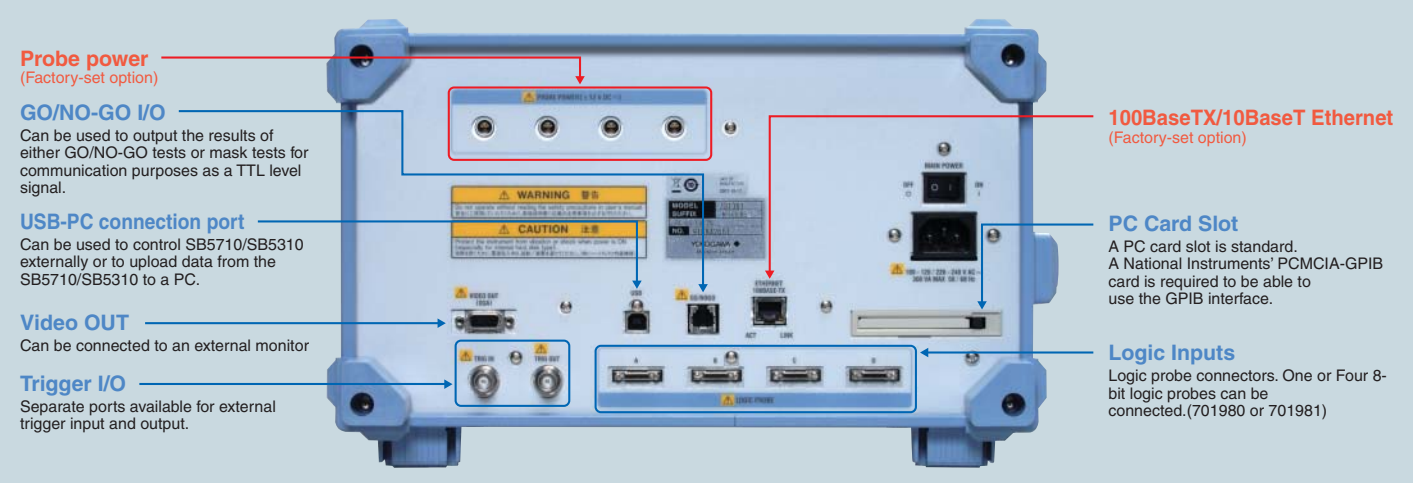

Figure.23 Example of logic bus, symbol display

Versatile Connectivity



Efficiently Save Only the Data You Need and Extract Only the Abnormal Waveforms

History Memory & Search

The SB5710/SB5310 divides its built-in 6.25 MW (Mpts) memory into a maximum of 2000 segments, and automatically saves the waveform data captured with the wide assortment of in-vehicle serial bus triggers into these segments. It comes equipped with a History Memory function that can recall past waveforms stored in the individually divided memory in this manner. No special settings whatsoever are required. This convenient function saves screen-updated waveform data to the automatically divided memory, and can recall it. With the History Memory, you can efficiently load only the needed portion of data captured by triggers into memory while monitoring the bus. Also, abnormal bus waveforms with unexpected glitches or noise can be extracted (searched for) from the History Memory and zoomed.

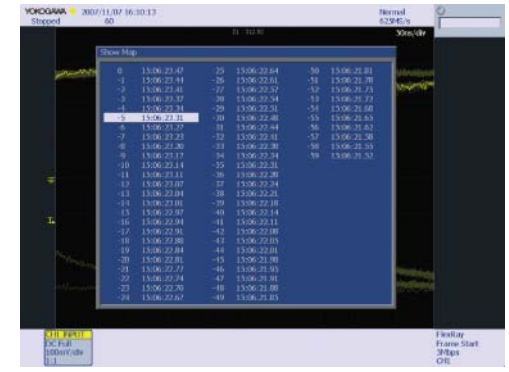

Figure.24 Multiple waveforms can be saved automatically into History Memory

Isolate Abnormal Waveforms

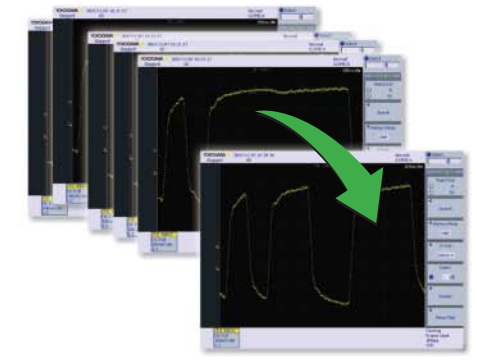
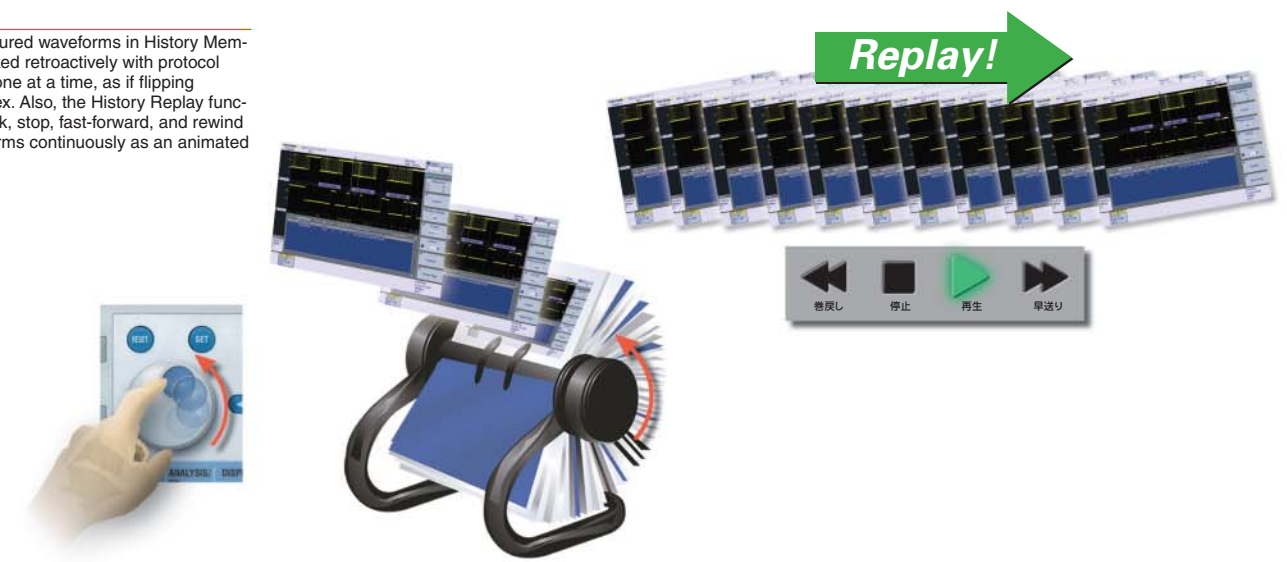

Figure.25 The History Memory function allows you to call up a maximum of 2,000 previously acquired waveforms and analyze the retained waveform data.

History Replay

Divided and captured waveforms in History Memory can be checked retroactively with protocol analysis results one at a time, as if flipping through a Rolodex. Also, the History Replay function can play back, stop, fast-forward, and rewind captured waveforms continuously as an animated image.





Models				
Model name (No.)	Max. sampling rate	Freq. BW	Max. record length	Input channels
SB5310 (701351)	5 GSps	1 GHz	6.25 MW (Mpts)	Analog 4 CH + Logic 8-bit
SB5710 (701361)	5 GSps	1 GHz	6.25 MW (Mpts)	Analog 4 CH + Logic 32-bit

FlexRay Analysis Functions	
FlexRay bus	FlexRay Protocol Version 2.1
Bit rate	10Mbps, 5 Mbps, 2.5 Mbps
●Trigger function	
Source	CH1 to CH4
Type	FlexRay bus signal (BP and BM signals input through differential probe) Selectable from the following options: Frame Start: Trigger at Frame Start ID/Data: Trigger at Indicator/ID/Cycle Count/Data ID/Data OR: Trigger at OR condition of Indicator/ID/Cycle Count/Data Error Trigger: Trigger at CRC/BSS/FES errors OR condition for these errors can be set Message/Signal: FIBEX Message (ID), Signal (ID/Data)

●Analysis function	
Source	CH1 to CH4, M1 to M4
Analyzable number of frames:	Max. 600
Min. required sampling rate for analysis:	Eight (8) times or more of the FlexRay signal bit rate
Analyzable Fields	Header Segment, Payload Segment, Trailer Segment
Display of analysis results:	
●Simple:	Displays number of frame (No.), Frame ID/Message, Data (hexadecimal notation/physical value)
●Detail:	Displays number of frame (No.), Time, Segment (Static, Dynamic), Payload preamble indicator, Null frame indicator, Sync frame indicator, Startup frame indicator, Frame ID/Message, Payload length, Cycle count, Information (errors), Payload data displays in hexadecimal notation/physical value.
Field Jump	
●Field Jump:	When the zoom link function is enabled, the zoom position can be moved to the head of the specified field of the frame that is highlighted in the analysis result list. Select the field from Frame ID, Payload length, Header CRC, Cycle count, Data, CRC

Automatic measurement of waveform parameters:	
Waveform parameters:	BSS Interval, FBSS Interval, BSSFES
Statistical items:	Max, Min, Mean, σ , Cnt
●Bus drive electrical test:	FlexRay EPL-Specification V2.1
Receiver Test@TP4:	<Measures from BP-BM and RxEN waveforms> dBDRxia(Active Reaction Time) dBDRxai(Idle Reaction Time) <Measures from BP-BM and RxD waveforms> dBDRx10(Receiver delay(Negative edge)) dBDRx01(Receiver delay(Positive edge)) dRxAsym(Receiver delay mismatch IdBDRx10- dBDRx01)

Transmitter Test@TP1	<Measures from TxD and BP-BM waveforms> dBDTx10(Transmitter delay(Negative edge)) dBDTx01(Transmitter delay(Positive edge)) dBusTx10(Fall time differential bus voltage) dBusTx01(Rise time differential bus voltage) dTxAsym(Transmitter delay mismatch IdBDTx10- dBDTx01) uBDTx(Absolute value of uBus IBP-BM), when sending/when idle) <Measures from TxEN and BP-BM waveforms > dBDTxia(Propagation delay Idle -> Active) dBDTxai(Propagation delay Active -> Idle) dBusTxia(Transition time Idle -> Active) dBusTxai(Transition time Active -> Idle)
----------------------	--------------------------------------------------------------------------------------------------------------------------------------------------------------------------------------------------------------------------------------------------------------------------------------------------------------------------------------------------------------------------------------------------------------------------------------------------------------------------------------------------------------------------------------------------------------------------------------------

Eye-diagram test	Test items: Mask Test/Eye parameter test Mask Test Item: Wave Count/Wave Count%/Sample Point Count/Sample Point Count% Eye Parameter Item: Vtop/Vbase/rtop/obase/Tcrossing1/Tcrossing2/Vcrossing/Crossing%/Eye Height/EyeWidth/QFactor/Jitter/Jitter2/Duty Cycle Distortion%/Rise/Fall
Saving of the data of the analysis result list	Saves the data of the simple display and detail display of the analysis result list in CSV format (.csv extension).

●Search function	
Data search	Search the waveform by specifying a field or frame condition. If a waveform that matches the condition is found, the zoom box moves to that point and displays the specified waveform in the zoom window.

CAN Analysis Functions	
CAN bus	CAN Version 2.0B
Bit rate	Set any of the following bit rates: 1 M, 500 k, 250 k, 125 k, 83.3 k, 33.3 k [bps], or an arbitrary bit rate from 10 k to 1 M [bps] (0.1 kbps resolution). Supports High speed CAN (ISO11898) and Low speed CAN (ISO11519-2).
●Trigger function	
Source	CH1 to CH4
Type	Selectable from the following options: SOF: Activates a trigger on the SOF (Start of Frame). Error Frame: Activates a trigger on an error frame. ID Std/Data: Activates a trigger on a data frame or remote frame (ID: standard format). ID Ext/Data: Activates a trigger on a data frame or remote frame (ID: extended format). ID/Data OR: Activates a trigger on the OR conditions of four types of data frames or remote frames. Select standard or extended format for each ID. Message/Signal: CAN Message (ID), Signal (ID/Data)
●Analysis function	
Source	CH1 to CH4, M1 to M4
Analyzable number of frames:	Max. 3000
Analyzed frames	Data frame, remote frame, error frame, and overload frame.

Display of analysis results:	
●Simple	Displays the analysis number (No.), frame type (Frame), ID in hexadecimal notation/symbol (ID/Message), Data in hexadecimal notation/symbol, and ACK slot state.
●Detail	Displays the analysis number (No.), frame type (Frame), time from the trigger position (Time (ms)), ID in hexadecimal notation/symbol (ID/Message), DLC in hexadecimal notation, Data in binary notation (Data (Bin))/Symbol (Signal), Data in hexadecimal notation/symbol, CRC sequence in hexadecimal notation, and ACK slot state.
Field Jump	
●Field Jump:	When the zoom link function is enabled, the zoom position can be moved to the head of the specified field of the frame that is highlighted in the analysis result list. Select the field from SOF, ID, Control Field, Data Field, CRC, ACK.
Saving of the data of the analysis result list	Saves the data of the simple display and detail display of the analysis result list in CSV format (.csv extension).

●Search function	
Data search	Search the waveform by specifying a field or frame condition. If a waveform that matches the condition is found, the zoom box moves to that point and displays the specified waveform in the zoom window.
●Stuff Bit Function	
Stuff bit computation	Extracts stuff bits from the CAN bus waveform and displays them as a MATH waveform (MATH1 to MATH4).
Stuff bit display	Stuff bit (s) can be identified in the decode display.

LIN Analysis Functions	
LIN bus	LIN1.3 or LIN2.0
Bit rate	Set any of the following bit rates: 19200, 9600, 4800, 2400, 1200 [bps], or an arbitrary bit rate from 1000 to 20k [bps] (0.1kbps resolution).
●trigger function	
Source	CH1 to CH4, Logic PodA*1
Type	Selectable from the following options: Break + Synch: Activates a trigger on the (Break + Synch). ID/Data: Activates a trigger on a ID/Data and/or their combination ID/Data OR: Activates a trigger on the OR conditions of four types of ID/Data conditions. Error: Activates a trigger on a frame at which error occurred. Activates a trigger on the OR conditions of error conditions (Error conditions) Parity Error, Checksum Error, Synch Error, Timeout Error (Slave Not Responding Error, Header Timeout Error, Response Timeout Error), Framing Error
●Analysis functions	
Source	CH1 to CH4, Logic PodA*1, M1 to M4
Analyzable number of frames:	Max. 3000
Analyzed Fields	Break, Synch, ID, Data, Checksum, Information (ID parity error, Checksum error, Time Out error, Synch error, Framing error and Wakeup signal)
Display of analysis results:	
●Simple	Displays the analysis number (No.), ID in hexadecimal notation, Data in hexadecimal notation, and CheckSum in hexadecimal notation.
●Detail	Displays the analysis number (No.), time from the trigger position (Time (ms)), ID in hexadecimal notation, ID-Field in hexadecimal notation, Data in binary notation (Data (Bin)), Data in hexadecimal notation (Data), CheckSum in hexadecimal notation, and Information.
Field Jump	
●Field Jump:	When the zoom link function is enabled, the zoom position can be moved to the head of the specified field of the frame that is highlighted in the analysis result list. Select the field from Break, Synch, ID, Data, Checksum.
Saving of the data of the analysis result list	Saves the data of the simple display and detail display of the analysis result list in CSV format (.csv extension).

●Search function	
Data search	Search the waveform by specifying a field or frame condition. If a waveform that matches the condition is found, the zoom box moves to that point and displays the specified waveform in the zoom window.
●UART Analysis Functions	
Bit rate	Set any of the following bit rates: 1200bps, 2400bps, 4800bps, 9600bps, 19200bps, 38400bps, 57600bps, 115200 [bps], or an arbitrary bit rate from 1000 to 200 k [bps] (0.1kbps resolution).
●Trigger function	
Source	CH1 to CH4, Logic PodA*1
Data Format	Selectable from the following options: ●8bit Data (Non-Parity bit) ●7bit Data + Parity bit ●8bit Data + Parity bit Selectable from the following options: ●Data: Activates a trigger on a any data(up to 4-byte) ●Error trigger: Activates a trigger on a frame which Parity or Framing error is occurred. ●Every Data: Activate a trigger on every stop bit.
Type	
●Analysis function	
Source	CH1 to CH4, Logic PodA1*1, M1 to M4
Analyzable number of frames:	Max. 3000
Analyzed Fields	Data, Information (Parity error, Framing error)
Display of analysis results:	
●Simple	Displays the analysis number (No.), Data in hexadecimal notation/ASCII notation, Information
●Detail	Displays the analysis number (No.), time from the trigger position (Time (ms)), Data in binary notation (Data (Bin)), Data in hexadecimal notation/ASCII notation (Data) and Information.
●Grouping	Displays the specified grouping indication defined by byte space.
Saving of the data of the analysis result list	Saves the data of the simple display and detail display of the analysis result list in CSV format (.csv extension).

●Search function	
Data search	Search the waveform by specifying a field or frame condition. If a waveform that matches the condition is found, the zoom box moves to that point and displays the specified waveform in the zoom window.

I ² C Analysis Functions	
I ² C bus	Bus transfer rate: Up to 3.4 Mbits/s Address mode: 7 bits/10 bits
●Trigger function	
Source	CH1 to CH4, Logic PodA*1
Type	Select from the following five trigger types. Every Start: Activate a trigger when a start condition is detected Address&Data: Activate a trigger based on the comparison against the specified address and data Non-ACK: Activate a trigger when Nack is detected General Call: Activate a trigger based on the comparison against the second byte pattern of the general call address Start Byte/HS Mode: Activate a trigger on the start byte or the master address of HS mode The address type of the Address&Data trigger can be selected from the following three types. ●7bit address ●7bit + Sub Adr ●10bit Address

●Analysis function	
Source	CH1 to CH4, Logic PodA*1, M1 to M4
Analyzable number of data:	Max. 40000-byte
Display of analysis results:	
●Simple	Displays the analysis number (No.), Start/Stop conditions (S/P), Data in hexadecimal notation, Address/Data (Form), Read/Write (R/W), ACK Displays the analysis number (No.), Start/Stop conditions (S/P), time from the trigger position (Time (ms)), Data in binary notation (Data (Bin)), Data in hexadecimal notation (Data), Address/Data (Form), Read/Write (R/W), ACK and Information.
●Detail	Displays the analysis number (No.), Start/Stop conditions (S/P), time from the trigger position (Time (ms)), Data in binary notation (Data (Bin)), Data in hexadecimal notation (Data), Address/Data (Form), Read/Write (R/W), ACK and Information.
Saving of the data of the analysis result list	Saves the data of the simple display and detail display of the analysis result list in CSV format (.csv extension).

●Search function	
Data search	Set the address pattern, data pattern, and Acknowledge bit condition and search the waveform. If a waveform that matches the condition is found, the zoom box moves to that point and displays the specified waveform.
●SPI Analysis Functions	
●Trigger function	
Source	CH1 to CH4, Logic PodA*1
Type	Three-wire or Four wire Activate a trigger by comparing data from an arbitrary byte counts after the assertion of the CS. The length of data that is compared can be set to 1 to 4 bytes.
●Analysis function	
Source	CH1 to CH4, Logic PodA*1, M1 to M4
Analyzable number of data:	Max. 40000-byte
Analyzed Fields	Data
Display of analysis results:	
●Simple	Displays the analysis number (No.), Data1 in hexadecimal notation (Data1 (H)), Data2 in hexadecimal notation (Data2(H)), CS Displays the analysis number (No.), time from the trigger position (Time (ms)), Data1 in binary notation (Data1(B)), Data2 in binary notation (Data2 (B)), Data1 in hexadecimal notation (Data1(H)), Data2 in hexadecimal notation (Data2 (H)), CS (CS signal status or the CS signal name with high precedence).
●Detail	Displays the analysis number (No.), Data1 in hexadecimal notation (Data1(H)), Data2 in hexadecimal notation (Data2 (H)), CS (CS signal status or the CS signal name with high precedence).
Saving of the data of the analysis result list	Saves the data of the simple display and detail display of the analysis result list in CSV format (.csv extension).

●Search function	
Data search	Set the data pattern and search the waveform. If a waveform that matches the condition is found, the zoom box moves to that point and displays the specified waveform.
●Basic Specifications	
●Analog Inputs	
Input channels:	4 (CH1 to CH4)
Input coupling:	AC, DC, GND, DC50 Ω
Input impedance:	1 M Ω \pm 1.0% approx. 20 pF 50 Ω \pm 1.5%
Voltage axis sensitivity:	For 1 M Ω input: 2 mV/div to 5 V/div (steps of 1-2-5) For 50 Ω input: 2 mV/div to 500 mV/div (steps of 1-2-5)
Maximum input voltage:	For 1 M Ω input: 150 Vrms CAT I (when frequency is under 1 kHz) For 50 Ω input: 5 Vrms or less and 10 Vpeak or less
Vertical (voltage) axis sensitivity:	
DC accuracy*2:	For 1 M Ω input: \pm (1.5% of 8 div + offset voltage accuracy) For 50 Ω input: \pm (1.5% of 8 div + offset voltage accuracy)
Offset voltage axis accuracy*2:	2 mV/div to 50 mV/div: \pm (1% of setting + 0.2 mV) 100 mV/div to 500 mV/div: \pm (1% of setting + 2 mV) 1 V/div to 5 V/div: \pm (1% of setting + 20 mV)
Frequency characteristics*2, *3	(Attenuation point of -3 dB when inputting a sinewave of amplitude \pm 2 div or equivalent): For 50 Ω input 0.5 V/div to 10 mV/div: DC to 1 GHz 5 mV/div: DC to 750 MHz 2 mV/div: DC to 600 MHz For 1 M Ω input (from the probe tip when using the PB500 dedicated passive probe) 5 V/div to 10 mV/div: DC to 500 MHz 5 mV/div to 2 mV/div: DC to 400 MHz

A/D conversion resolution	8 bits (25 LSB/div) Max. 12 bits (in high resolution mode)
Probe attenuation settings	1:1, 2:1, 5:1, 10:1, 20:1, 50:1, 100:1, 200:1, 500:1, 1000:1, 1A:1V, 10A:1V, 100A:1V
Bandwidth limit	For each channel, selectable from: FULL, 200 MHz, 20 MHz, 8 MHz, 4 MHz, 2 MHz, 1 MHz, 500kHz, 250 kHz, 125 kHz, 62.5 kHz, 32 kHz, 16 kHz, and 8 kHz Achieved by combining the analog filter (200 MHz, 20 MHz) and digital filter (IIR + FIR)
Maximum sample rate	Realtime sampling mode When interleave mode is ON: 5 GS/s When interleave mode is OFF: 2.5 GS/s
Repetitive sampling mode:	2.5 TS/s
Max. record length	6.25 MW (Mpts)
Maximum acquisition rate	For 1.25 MW (Mpts) record length 60 waveforms/s/channel For 12.5 kW (kpts) record length 9,000 waveforms/s/channel For 2.5 kW (kpts) record length 25,000 waveforms/s/channel 400 ns or less (equivalent to 2,500,000 waveforms/s for each channel)
Dead time for N single*4	
●Logic Inputs	
Compatible probes	701980 and 701981 (8-bit input)
Maximum toggle frequency*5	When using the 701980: 100 MHz When using the 701981: 250 MHz
Maximum input voltage	\pm 40 V (DC + ACpeak) or 28 Vrms at a frequency of 1 kHz or less

General Specifications	
Rated supply voltage	100 to 120 VAC or 220 to 240 VAC (automatic switching)
Rated supply frequency	50/60 Hz
Maximum power consumption	300 VA
External dimensions	350 (W) \times 200 (H) \times 285 (D) mm (with printer cover put away, excluding handle and other projections) Approx. 7.7 kg (without options)
Weight	
Operating Temperature	5 to 40 $^{\circ}$ C
*1: Pod A (8-bit) is only available regardless of models	
*2: Values measured under standard operating conditions after 30-minute warm-up and calibration with the time base set to internal clock. Ambient temperature: 23 \pm 5 $^{\circ}$ C Ambient humidity: 55 \pm 10% RH Power supply voltage and frequency tolerance: Within 1% of rated value	
*3: Values for a repeating phenomena. The frequency bandwidth of a single burst frequency bandwidth is the smaller of the two values, DC to the sampling frequency/2.5 and the frequency bandwidth of the repeating phenomena.	
*4: No change in the acquisition rate with an increase or decrease in the number of channels.	
*5: Values measured under standard operating conditions.	

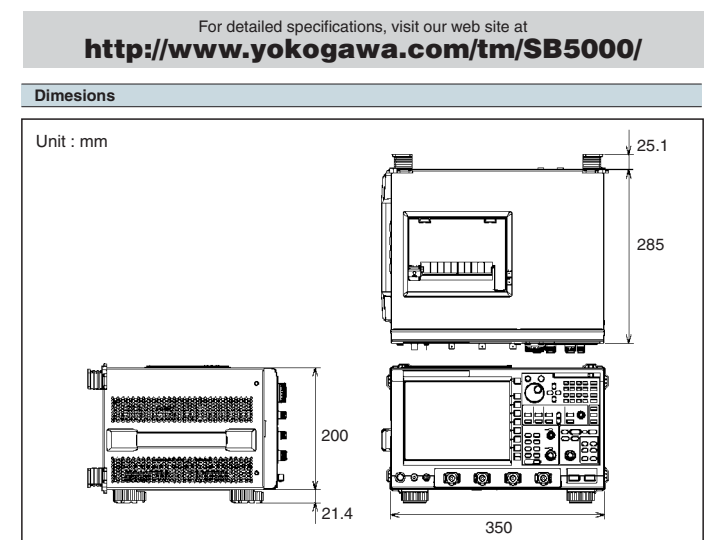

Model and Suffix Codes of SB5710, SB5310

Model	Suffix Code	Description
701351		SB5310: 4 ch 1.0GHz + Logic 8-bit Max. 5GS/s(2.5GS/s/ch), 6.25 MW (Mpts)/ch
701361		SB5710: 4 ch 1.0GHz + Logic 32-bit Max. 5GS/s(2.5GS/s/ch), 6.25 MW (Mpts)/ch
Power Cable	-D	UL/CSA standard
	-F	VDE standard
	-Q	BS standard
	-R	AS standard
	-H	GB standard
Help menu language	-HE	English Help
	-HC	Chinese Help
	-HK	Korean Help
Options	/B5	Built-in printer
	/P4*1	4 Probe power terminals on rear panel
	/C8*2	Built-in HDD + Ethernet interface
	/C10*2	Ethernet interface
	/G2*3	User-defined math function
	/G4*3	Power Supply Analysis Function

*1: Please order /P4 option if you use either current probes or differential probes such as 701920, 701922.

*2: Choose either one

*3: Choose either one

Accessories (Optional)

Name	Model	Specification
PB500 (10:1 passive probe)	701943	10 M Ω (10:1), 500 MHz, 1.5 m(one per order)
PBA2500 (2.5 GHz active probe)	701913	2.5 GHz BW
PBA1500 (1.5 GHz active probe)	701914	1.5 GHz BW
PBA1000 (1.0 GHz active probe)	701912	1.0 GHz BW
PBD2000(2.0 GHz differential probe)	701923	2.0 GHz BW
Miniature passive probe	701941	10:1, DC to 500 MHz, 1.2 m
100:1 high voltage probe	701944	DC to 400 MHz, 1.2 m
100:1 high voltage probe	701945	DC to 250 MHz, 3 m
PBL5000 (5 GHz probe)	701974	5 GHz BW
DC block	701975	For 50 Ω input, SMA connector
FET probe*1	700939	900 MHz BW
Logic probe	701980	1 M Ω /10 pF, 100 MHz toggle frequency
Logic probe	701981	10 k Ω /9 pF, 250 MHz toggle frequency
Differential probe*1	701921	DC to 100 MHz BW/Max. \pm 700 V
Differential probe*1	701922	DC to 200 MHz BW/Max. \pm 20 V
Differential probe	701924	DC to 1 GHz BW/Max. \pm 25 V
Differential probe*1	700924	DC to 100 MHz BW/Max. \pm 1400 V
Differential probe*1	701920	DC to 500 MHz BW/Max. \pm 12 V
Current probe	701928	DC to 100 MHz BW, 30 Arms
Current probe	701929	DC to 50 MHz BW, 30 Arms
Current probe*1	701933	DC to 50 MHz BW, 30 Arms
Current probe*1	701932	DC to 100 MHz BW, 30 Arms
Current probe	701931	DC to 2 MHz BW, 500 Arms
Current probe	701930	DC to 10 MHz BW, 150 Arms
Printer roll	B9850NX	30 m roll, 5 rolls/order
Rack mount kit	701983-01	EIA standard-compliant
	701983-02	JIS standard-compliant
Xviewer	701992-SP01	standard type
	701992-GP01	with computation function
Probe stand	701919	Circular Base, 1 arm
Symbol Editor	(free)	DBC/FIBEX Symbol definition

*1: /P4 option is required on the SB5710/SB5310 main unit.

Company names and product names appearing in this document are the registered trademarks or trademarks of their respective companies.

Yokogawa's Approach to Preserving the Global Environment

- Yokogawa's electrical products are developed and produced in facilities that have received ISO14001 approval.
- In order to protect the global environment, Yokogawa's electrical products are designed in accordance with Yokogawa's Environmentally Friendly Product Design Guidelines and Product Design Assessment Criteria.

Standard Accessories

Name	Qty
Power Cable	1
PB500 passive probe	4
Printer roll paper (when option /B5 is specified)	1
User's manual (1 set)	1
Front panel cover	1
Rubber leg cap (2 per order)	2
Soft case	1

Related products

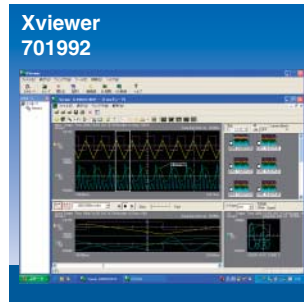

Note



- Before operating the product, read the user's manual thoroughly for proper and safe operation.