

# MODEL TA320 TIME INTERVAL ANALYZER

**SANO Tsuyoshi \*1 KATANO Kazuya \*1 IWATSUBO Masakatsu \*1 SHIMMEN Keizo \*1**

---

*We have developed Model TA320 Time Interval Analyzer which features a 100-ps time resolution, 300-ps rms internal jitter, and 14-MS/s continuous sampling rate. The analyzer has been developed along the design concepts of inexpensiveness, compactness and easy operation. The TA320 analyzer is equipped with such functions as a multiwindow to meet the needs of the optical-disk market. In addition, the analyzer has generous statistical-calculation data items that are useful for signal analyses from different angles of view.*

---

## INTRODUCTION

With the advance of multimedia technologies, digital circuits are becoming faster and faster. Consequently, just a single bit error will cause the circuit to malfunction. Time interval analyzers, which measure time margins between clock signals and digital data signals, have therefore, among other measuring instruments, become increasingly important today. In 1991, Yokogawa Electric released the high-resolution TA1100 time interval analyzer to enter the time-measuring marketplace. It also released the compact, inexpensive TC110/120 universal counters in 1993, which are now in use in R & D labs and production lines. Taking advantage of these time-measuring techniques, Yokogawa has developed the advanced, compact, low-cost TA320 time interval analyzer that reflects market needs. The TA320 analyzer employs a large LCD display and touch-sensitive screen to enable signal measurement and data analysis with intuitive and smooth operation. As a result, the instrument is easy to use in a wide range of applications, from optical disks, such as digital video disks, among others, to R & D labs through to production lines. Figure 1 is an external view of the TA320 time interval analyzer.

---

\*1 Measuring Instruments Business Division

## CIRCUIT CONFIGURATION AND MEASURING PRINCIPLE

### 1. Circuit Configuration

Figure 2 illustrates a block diagram of the TA320 time interval analyzer. Signals being measured are sent to the IN terminals of channels A and B, guided through input-coupling (AC/DC) and input-impedance-transforming (50  $\Omega$ /1 M $\Omega$ )

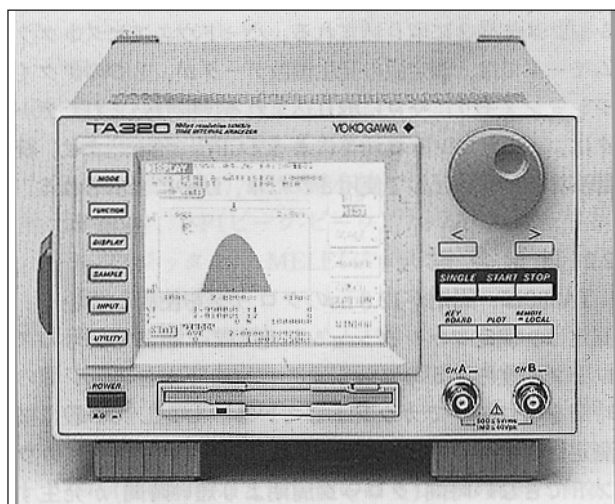

**Figure 1** External View of TA320 Time Interval Analyzer

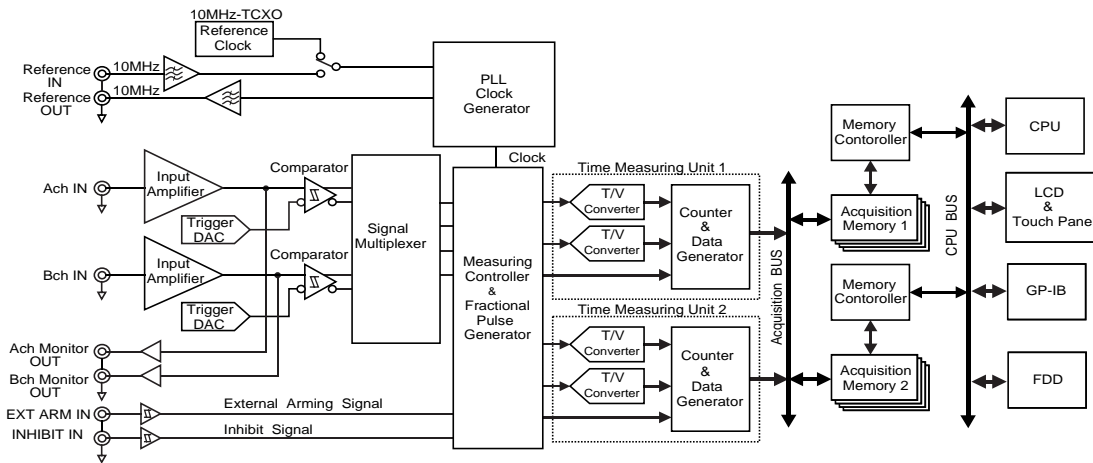

**Figure 2** Block Diagram of TA320 Time Interval Analyzer

circuitry, and then converted to low-impedance signals at the input amplifiers. These signals are further converted by the respective comparators to binary signals appropriate for the trigger voltage. As monitoring signals, output signals from the input amplifiers are tapped at the monitor terminals at a level approximately one fourth the magnitude of the input signals. Thus, using the tapped signals, the operator can check what kinds of waveforms he/she is measuring. This is especially advantageous when making measurements using probes dedicated to oscilloscopes since the operator can adjust the probe for optimum phase compensation while observing the monitoring signals. Comparator output signals are scanned by the multiplexer to select binary signals appropriate for a given measurement function (period, pulse width, A-to-B interval, etc.), and then supplied to the measurement control circuit. The measurement control circuit in turn controls measurement by means of the number of events, gate time, external arming signal, and inhibit signal. The circuit also generates fractional pulses appropriate for the signals being measured. These pulses are converted to voltage-mode values through the time/voltage converters. Then, the duration of these values are measured at a 100-ps resolution to be added to the values of the counters. The resulting values form a single data item of measurement, enabling continuous measurement by alternately actuating the two time-measuring units.

Model TA320 has two sampling modes: a time stamp mode and a hardware histogram mode. In the time stamp mode, the analyzer stores measured values in acquisition memory 1 and time-stamp data (elapsed time) in acquisition memory 2. In the hardware histogram mode, data on the frequency of each measured value are alternately saved in these two acquisition memories. Data thus captured are read into the CPU by the memory controllers for use in statistical calculations or for display on the LCD.

## 2. Measuring Principle

The TA320 analyzer uses a clock with a period of 12.8 ns. Using the clock, it counts the time interval between any two given

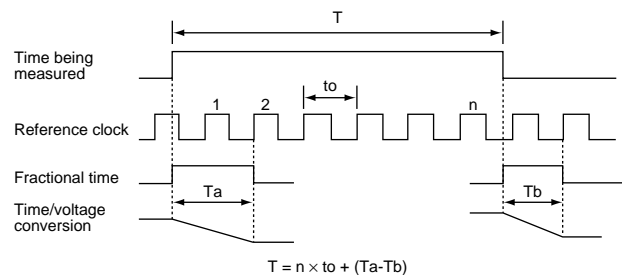

**Figure 3** Measuring Principle Based on Time/Voltage Conversion

rising or falling edges on the slopes of a signal being measured, depending on the measurement function. Since, in general, signals that are being measured are asynchronous to clocks, there are zones of time (time intervals shorter than the clock period) which cannot be counted with a clock. These time zones are called fractional times. Fractional times lie at the starting and ending edges of a measurement interval.

Given that the pulse width of a signal being measured is  $T$ , the period of a clock is  $t_o$ , and the durations of fractional pulses are  $T_a$  and  $T_b$ , then pulse width  $T$  can be represented by the sum of two terms, i.e.,  $N \cdot t_o$  which is the integer multiples of the clock period, and  $(T_a - T_b)$  which is the difference between the two fractional times, as shown below:

$$T = N \cdot t_o + (T_a - T_b) \text{ ----- (1)}$$

In order to achieve high-resolution time measurement by means of hardware, the TA320 analyzer produces extra pulses (fractional pulses) with the duration of the fractional time plus one clock period to submit them to a time-to-voltage (T/V) conversion (Figure 3). During fractional times  $T_a$  and  $T_b$ , the constant-current circuits charge capacitors, with the values of the charged voltages representing the duration of the fractional pulses. Next, the charged voltage signals are converted to digital values with the high-resolution A/D converters. The adders sum the values of the digital counters and fractional times. Since

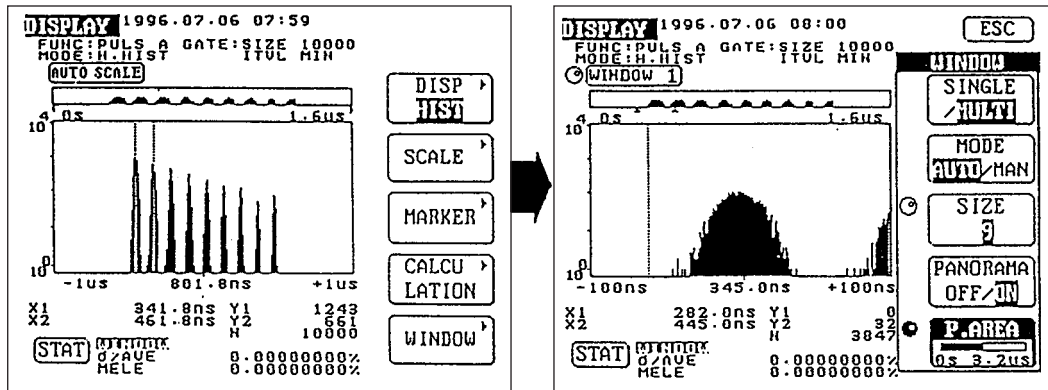

Figure 4 Multiwindow

formula (1) above has been implemented by means of hardware, it has become possible for the TA320 analyzer to sample data at a rate as fast as 14 MS/s and provide a hardware histogram mode.

## MAJOR FEATURES

### 1. Multiwindow Function (Figure 4)

The TA320 analyzer shows two or more histograms (frequency distributions) when, in a single measurement for histogram representation, measured data values center around each of the multiple points on the X-axis. The analyzer can show all histograms on just one screen. In addition, if the statistical data values of each histogram need to be analyzed in detail, the operator can set off each bar of the histograms in a window to sequentially view those histograms one at a time. The feature in which multiple windows are thus set to show details on each histogram is called the multiwindow. The operator can configure a maximum of 16 windows at a time. Using the panorama view together with the multiwindow, the operator can immediately identify which of the multiple windows the histogram he/she is viewing belongs to. This feature is convenient in analyzing histograms with an optical disk's EFM (eight-to-fourteen modulation)-modulated pulse width of 3T to 11T.

### 2. Gating

The TA320 analyzer allows the operator to set the period for capturing data as the "gate." There are three types of gates where the operator measures the preset length of the gate time.

#### ● Event Gate

One measurement sample is called an event and this gate is set as a function of the number of events. The configurable range of the number varies depending on the sampling mode used.

- Time stamp mode: 1 to 32,000 events
- Hardware histogram mode: 1 to 99,999,999 events

#### ● Time Gate

This gate is set as a function of time. Not allowed to exceed the maximum number of events in each sampling mode, the maximum configurable length of time is 10 seconds.

#### ● External Gate

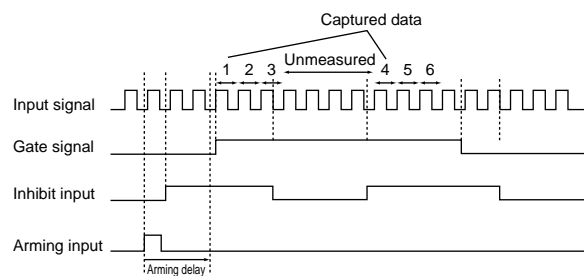

Figure 5 Relationship Between Gating, Inhibit and Arming Signals

This gate is controlled by the positive or negative polarity of an external input signal. Not allowed to exceed the maximum number of events in each sampling mode, the maximum controllable length of time is 320 seconds.

### 3. Inhibit

The operator can set a measurement-inhibited interval using the positive or negative polarity of an external input signal if he/she does not want to measure any particular part of an input signal. This feature is convenient in measuring intermittent signals.

### 4. External Arming

The operator can control the start of measurement using an external input signal. This feature is useful when, for example, measuring time data for the length of one circumference starting at the index point of a disk. Figure 5 explains the relationship between the gating, inhibit and arming features.

### 5. Generous Computing Data Items

The analyzer can calculate generous data items from given measured data values:

MAX (maximum), MIN (minimum), AVE (average),  $\sigma$  (standard deviation), P-P (peak-to-peak),  $\sigma$ /AVE (flutter),  $\sigma$ /T (jitter 1), MELE (jitter 2).

### 6. Generous Formats for Data Representations

The analyzer has four formats for data representations:

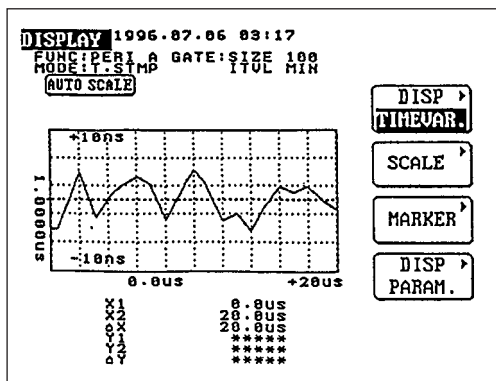

Figure 6 Variation with Time

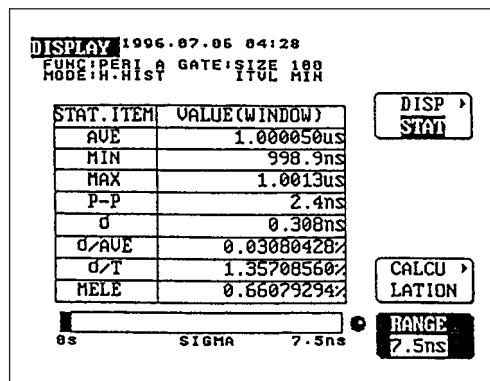

Figure 8 Statistics

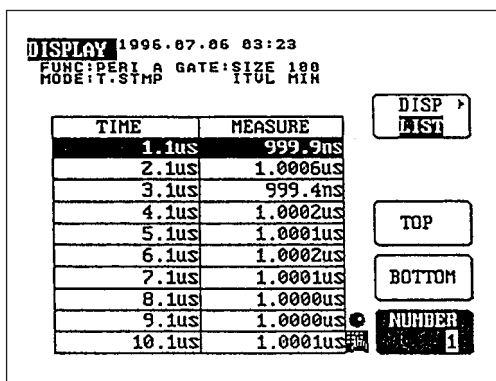

Figure 7 Listing of Measurements

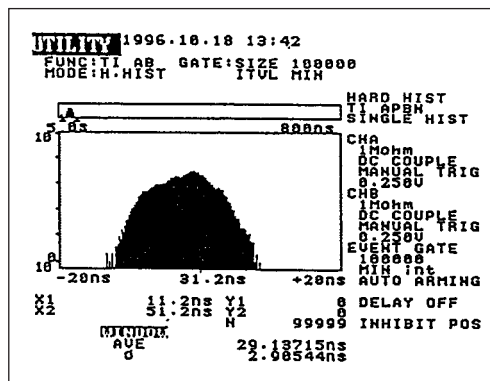

Figure 9 Data-to-Clock Measurement for Digital Video Disks

histogram, variation with time, listing, and statistics.

- Histogram (Figures 4 and 9)  
Effective for jitter analysis, as in the case of analyzing the dispersion of measured values
- Variation with Time (Figure 6)  
Effective in analyzing variations in measured values with time
- Listing (Figure 7)  
In the time stamp mode, this mode of display presents a numerical representation of variations in measured values with time. In the hardware histogram mode, it also numerically indicates the frequencies at which measured data values occur.
- Statistics (Figure 8)  
This mode of display shows the values of statistical calculations. It indicates the standard deviation as a bar graph at the bottom of the display.

## EXAMPLE OF APPLICATION

As an example of application, this section introduces the characterization of digital video disks. In the characterization, the amount of jitter in signals read from an optical pickup or in both these signals and the clock needs to be measured. Normally, the amount of jitter in digital video disks is a few nanoseconds.

Model TA320, whose internal jitter is only 300 ps rms, is therefore an efficient instrument for this application. Continuous measurement is another requirement in the characterization of digital video disks, demanding a sampling rate that permits measurement without missing any bits of signals. The analyzer, which has a continuous sampling rate of 14 MS/s, also satisfies this requirement. Figure 9 shows a graph of actual data-to-clock histograms that have been measured.

## CONCLUDING REMARKS

In this paper, we have introduced a function diagram, the measuring principle, and the features of the TA320 time interval analyzer. In the area of operability, we have also achieved easy operation and a fast response far better than those of conventional models. Consequently, Model TA320 is considered to be an instrument usable for a broad range of applications, from the optical-disk industry to other industrial segments such as telecommunications, semiconductors and electromechanics. ♦

## REFERENCE

- (1) Uozumi, T. How to Use Time Interval Analyzers. Denshi Gijutsu. The Nikkan Kogyo Shimben Ltd. Aug. 1996, pp. 61 to 66.